

DATA SHEET

PTN3151

**1 : 10 clock distribution device with
3-state outputs**

Product specification
File under Integrated Circuits, IC06

2002 Jan 14

1 : 10 clock distribution device with 3-state outputs**PTN3151****FEATURES**

- 1 : 10 LVTTTL clock distribution
- Low output-to-output skew
- Low output pulse skew
- Over voltage tolerant inputs and outputs
- LVTTTL-compatible inputs and outputs
- Distributed V_{CC} and ground pins reduce switching noise
- Balanced high-drive output currents: $I_{OH} = -32$ mA and $I_{OL} = 32$ mA
- Reduced power dissipation due to the state-of-the-art QuBICLP™ process
- Supply voltage range of 3.0 to 3.6 V
- Package options include plastic:
 - Small outline (D)
 - Shrink small outline (DB)
- Industrial temperature range from -40 to $+85$ °C.

DESCRIPTION

The PTN3151 is a high-performance 3.3 V LVTTTL clock distribution device. The PTN3151 enables a single clock input to be distributed to ten outputs with minimum output skew and pulse skew. The use of distributed V_{CC} and GND pins in the PTN3151 ensures reduced switching noise.

The PTN3151 is characterised for operation over the supply range 3.0 to 3.6 V, and over the industrial temperature range from -40 to $+85$ °C.

QUICK REFERENCE DATA

GND = 0 V; $T_{amb} = 25$ °C; $t_r = t_f \leq 3.0$ ns.

SYMBOL	PARAMETER	CONDITIONS	TYPICAL	UNIT
t_{PHL}/t_{PLH}	propagation delay A to Y_n	$C_L = 50$ pF; $V_{CC} = 3.3$ V	4.5	ns
C_I	input capacitance	$V_I = V_{CC}$ or GND	4	pF
C_O	output capacitance	$V_I = V_{CC}$ or GND	6	pF
C_{PD}	power dissipation capacitance	$C_L = 50$ pF; $f = 1$ MHz; notes 1 and 2	48	pF

Notes

1. C_{PD} is used to determine the dynamic power dissipation (P_D in μ W).

$P_D = C_{PD} \times V_{CC}^2 \times f_i + \sum (C_L \times V_{CC}^2 \times f_o)$ where:

f_i = input frequency in MHz;

f_o = output frequency in MHz;

$\sum (C_L \times V_{CC}^2 \times f_o)$ = sum of outputs;

C_L = output load capacitance in pF;

V_{CC} = supply voltage in Volt.

2. The condition is $V_I = GND$ to V_{CC} .

1 : 10 clock distribution device with 3-state outputs

PTN3151

FUNCTION TABLE

See note 1.

INPUTS		OUTPUTS
A	\overline{OE}	Y_n
L	H	Z
H	H	Z
L	L	L
H	L	H

Note

- 1. H = HIGH voltage level;
- L = LOW voltage level;
- Z = high-impedance OFF-state.

ORDERING INFORMATION

TYPE NUMBER	PACKAGES				
	TEMPERATURE RANGE	PINS	PACKAGE	MATERIAL	CODE
PTN3151D	-65 to +150 °C	24	SO	plastic	SOT137-1
PTN3151DB	-65 to +150 °C	24	SSOP	plastic	SOT340-1

PINNING

PIN	SYMBOL	DESCRIPTION
1, 7, 8, 12, 13, 17, 20 and 24	GND	ground (0 V)
2, 4, 9, 11, 14, 16, 18, 19, 21 and 23	Y_{10} to Y_1	outputs
3, 10, 15 and 22	V_{CC}	supply voltage
5	\overline{OE}	output enable input (active LOW)
6	A	data input

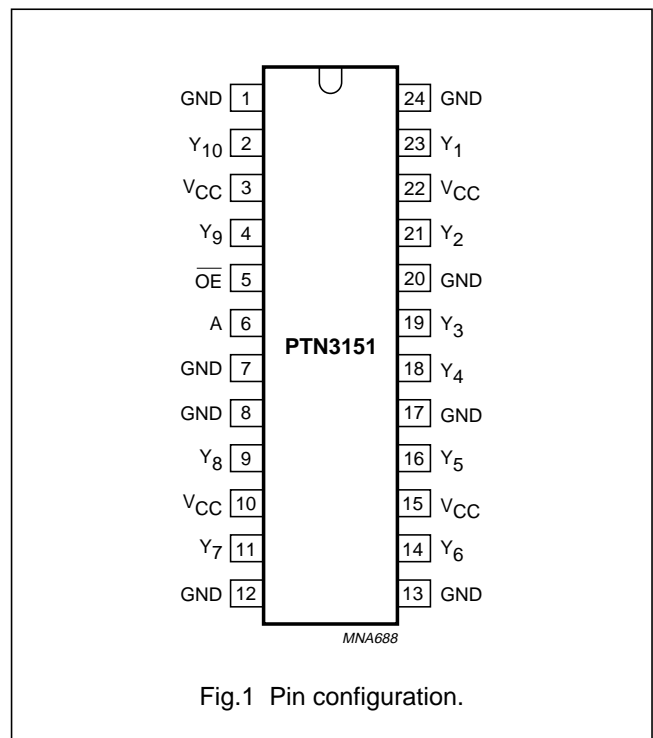
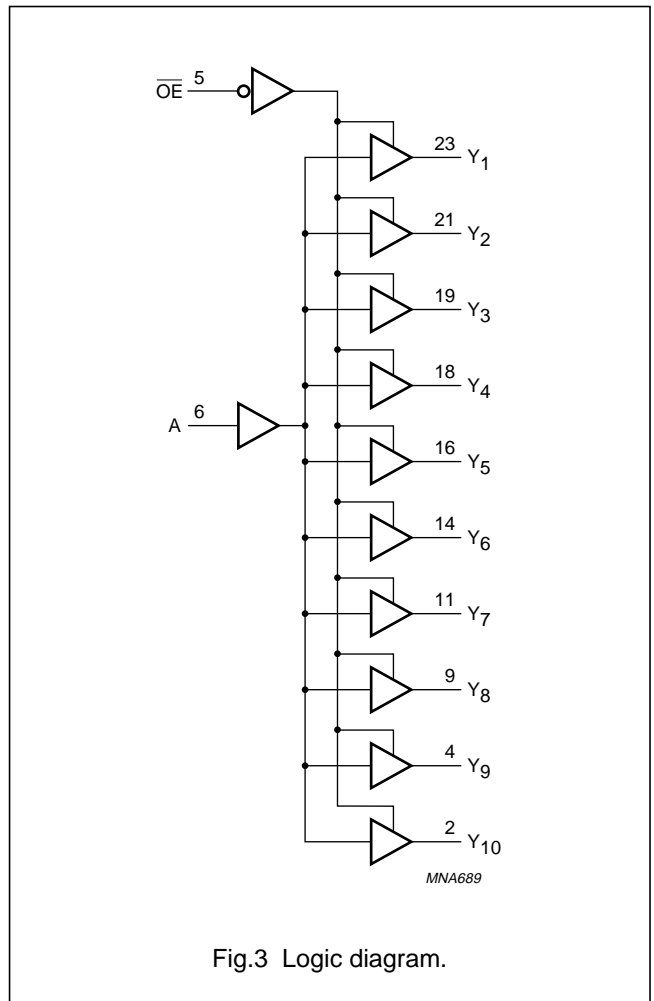
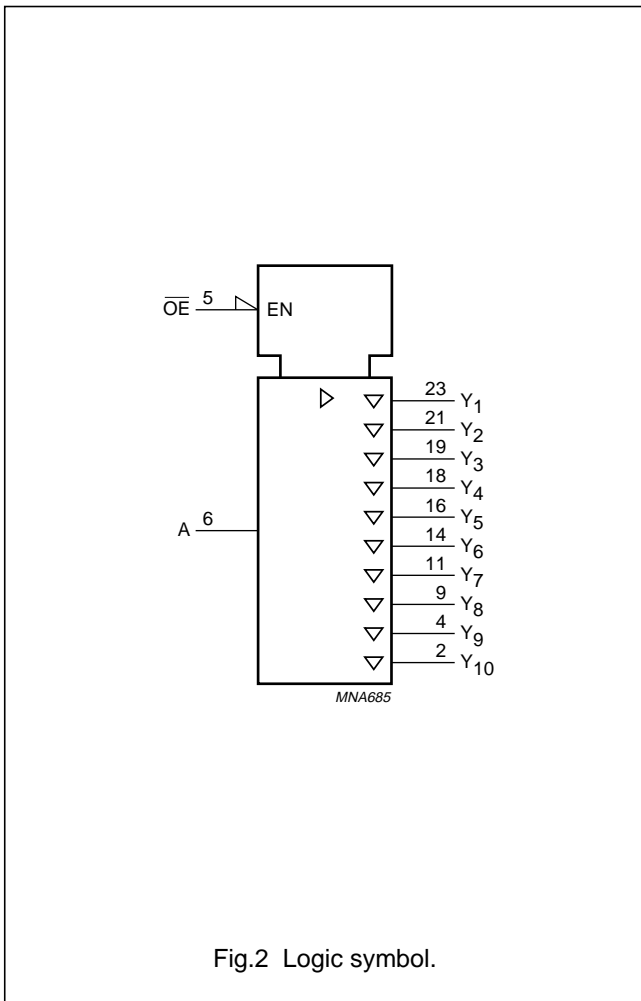

Fig.1 Pin configuration.

1 : 10 clock distribution device with 3-state outputs

PTN3151



1 : 10 clock distribution device with 3-state outputs

PTN3151

RECOMMENDED OPERATING CONDITIONS

See note 1.

SYMBOL	PARAMETER	CONDITIONS	MIN.	MAX.	UNIT
V_{CC}	supply voltage		3.0	3.6	V
V_{IH}	HIGH-level input voltage		2.0	5.5	V
V_I	input voltage		0	0.8	V
T_{amb}	ambient temperature	see DC and AC characteristics per device	-40	+85	°C
t_r, t_f	input rise and fall times	$V_{CC} = 3.3 \pm 0.3$ V	-	100	ns/V

Note

1. Unused pins (input or I/O) must be HIGH or LOW.

LIMITING VALUES

See notes 1 and 2.

SYMBOL	PARAMETER	CONDITIONS	MIN.	MAX.	UNIT
V_{CC}	supply voltage		-0.5	+4.6	V
V_I	input voltage	note 3	-0.5	+7.0	V
V_O	output voltage	note 3	-0.5	+3.6	V
I_{IK}	input clamp current	$V_I < 0$ V	-	-18	mA
I_{OK}	output clamp current	$V_I < 0$ V	-	-50	mA
I_O	output sink current		-	64	mA
I_{CC}, I_{GND}	V_{CC} or GND current		-	± 75	mA
T_{stg}	storage temperature		-65	+150	°C
P_D	maximum power dissipation				
	SO package	$T_{amb} = 55$ °C	-	0.65	W
	SSOP package	$T_{amb} = 55$ °C	-	1.7	W

Notes

1. Stresses beyond those listed may cause permanent damage to the device. These are stress ratings only and functional operation of the device at these or any other conditions beyond those indicated under recommended operating conditions is not implied. Exposure to absolute-maximum-rated conditions for extended periods may affect device reliability.
2. The performance capability of a high-performance integrated circuit in conjunction with its thermal environment can create junction temperatures which are detrimental to reliability. The maximum junction temperature of this integrated circuit should not exceed 150 °C.
3. The input and output negative voltage ratings may be exceeded if the input and output clamp currents are observed.

1 : 10 clock distribution device with 3-state outputs

PTN3151

DC CHARACTERISTICS

Over recommended operating conditions; voltages are referenced to GND (ground = 0 V).

SYMBOL	PARAMETER	TEST CONDITIONS		T _{amb} (°C)			UNIT
		OTHER	V _{CC} (V)	25			
				MIN.	TYP.	MAX.	
V _{IK}	input diode voltage	I _I = -18 mA	3.0	-	-	-1.2	V
V _{OH}	HIGH-level output voltage	I _{OH} = -32 mA	3.0	2.0	-	-	V
V _{OL}	LOW-level output voltage	I _{OL} = 32 mA	3.0	-	-	0.5	V
I _{LI}	input leakage current	V _I = GND or 5.5 V	3.6	-	-	±1.0	μA
I _{LO}	output leakage current	V _O = 2.5 V; note 1	3.6	-15	-	-150	mA
I _{OZ}	3-state output OFF-state current	V _O = 3 V or 0	3.6	-	-	±10	μA
I _{CC}	quiescent supply current	V _I = V _{CC} or GND; I _O = 0					
		outputs HIGH	3.6	-	-	0.3	mA
		outputs LOW	3.6	-	-	25	mA
	outputs disabled	3.6	-	-	0.3	mA	
C _I	input capacitance	V _I = V _{CC} or GND; f = 10 MHz	3.3	-	4	-	pF
C _O	output capacitance	V _O = V _{CC} or GND; f = 10 MHz	3.3	-	6	-	pF

Note

1. Not more than one output should be tested at a time, and the duration of the test should not exceed one second.

1 : 10 clock distribution device with 3-state outputs

PTN3151

AC CHARACTERISTICSGND = 0 V; $t_r = t_f \leq 3.0$ ns.

SYMBOL	PARAMETER	TEST CONDITIONS		MIN.	TYP.	MAX.	UNIT
		WAVEFORMS	C_L				
$V_{CC} = 3.3$ V; $T_{amb} = 25$ °C							
t_{PLH}/t_{PHL}	propagation delay A to Y_n	see Figs 4 and 7	50 pF	3.1	3.6	4.1	ns
t_{PZH}/t_{PZL}	propagation delay \overline{OE} to Y_n	see Figs 5 and 7		1.8	3.8	5.5	ns
t_{PHZ}/t_{PLZ}	propagation delay \overline{OE} to Y_n	see Figs 5 and 7		1.8	4.0	5.9	ns
$t_{sk(o)}$	output-to-output skew A to Y_n	see Figs 6 and 7		–	0.3	0.5	ns
$t_{sk(p)}$	pulse skew A to Y_n	see Figs 6 and 7		–	0.2	0.8	ns
$t_{sk(pr)}$	part-to-part skew A to Y_n	see Figs 6 and 7		–	–	1	ns
t_r	rise time A to Y_n	see Figs 4 and 7		–	–	–	ns
t_f	fall time A to Y_n	see Figs 4 and 7		–	–	–	ns
$V_{CC} = 3.3$ to 3.6 V; $T_{amb} = 0$ to 70 °C							
t_{PLH}/t_{PHL}	propagation delay A to Y_n	see Figs 4 and 7	50 pF	–	–	–	ns
t_{PZH}/t_{PZL}	propagation delay \overline{OE} to Y_n	see Figs 5 and 7		1.3	–	5.9	ns
t_{PHZ}/t_{PLZ}	propagation delay \overline{OE} to Y_n	see Figs 5 and 7		1.7	–	6.3	ns
$t_{sk(o)}$	output-to-output skew A to Y_n	see Figs 6 and 7		–	–	0.5	ns
$t_{sk(p)}$	pulse skew A to Y_n	see Figs 6 and 7		–	–	0.8	ns
$t_{sk(pr)}$	part-to-part skew A to Y_n	see Figs 6 and 7		–	–	1	ns
t_r	rise time A to Y_n	see Figs 4 and 7		–	–	1.5	ns
t_f	fall time A to Y_n	see Figs 4 and 7		–	–	1.5	ns

SWITCHING CHARACTERISTICSTemperature and V_{CC} coefficients over recommended operating free-air temperature and V_{CC} range; note 1.

SYMBOL	PARAMETER	CONDITIONS	MAX.	UNIT
$\Delta t_{PLH(T)}$	temperature coefficient of LOW-to-HIGH propagation delay A to Y_n (average value)	note 2	65	ps/10 °C
$\Delta t_{PHL(T)}$	temperature coefficient of HIGH-to-LOW propagation delay A to Y_n (average value)	note 2	45	ps/10 °C
$\Delta t_{PLH(V)}$	V_{CC} coefficient of LOW-to-HIGH propagation delay A to Y_n (average value)	note 3	–140	ps/100 mV
$\Delta t_{PHL(V)}$	V_{CC} coefficient of HIGH-to-LOW propagation delay A to Y_n (average value)	note 3	–120	ps/100 mV

Notes

1. These data were extracted from characterization material and are not tested at the factory.
2. $\Delta t_{PLH(T)}$ and $\Delta t_{PHL(T)}$ are virtually independent of V_{CC} .
3. $\Delta t_{PLH(V)}$ and $\Delta t_{PHL(V)}$ are virtually independent of temperature.

1 : 10 clock distribution device with 3-state outputs

PTN3151

AC WAVEFORMS

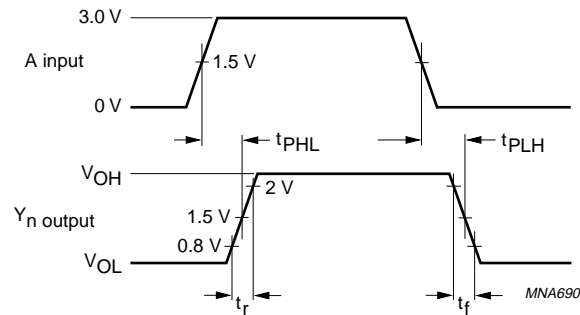

Fig.4 The input (A) to outputs (Y_n) propagation delays and rise and fall time.

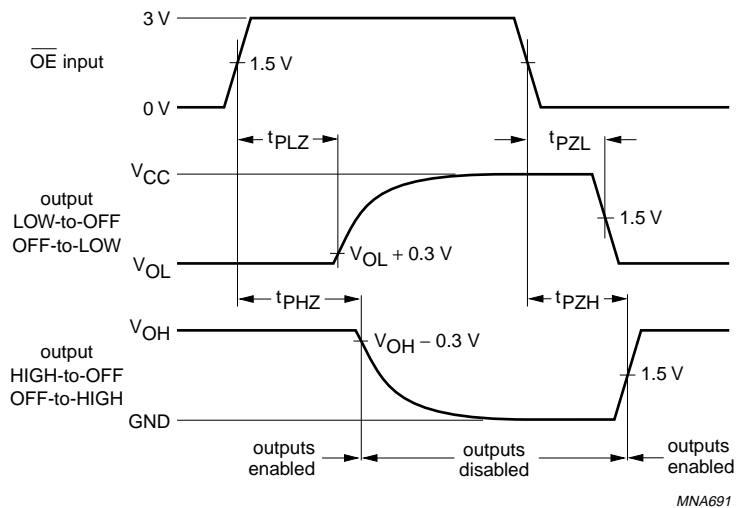
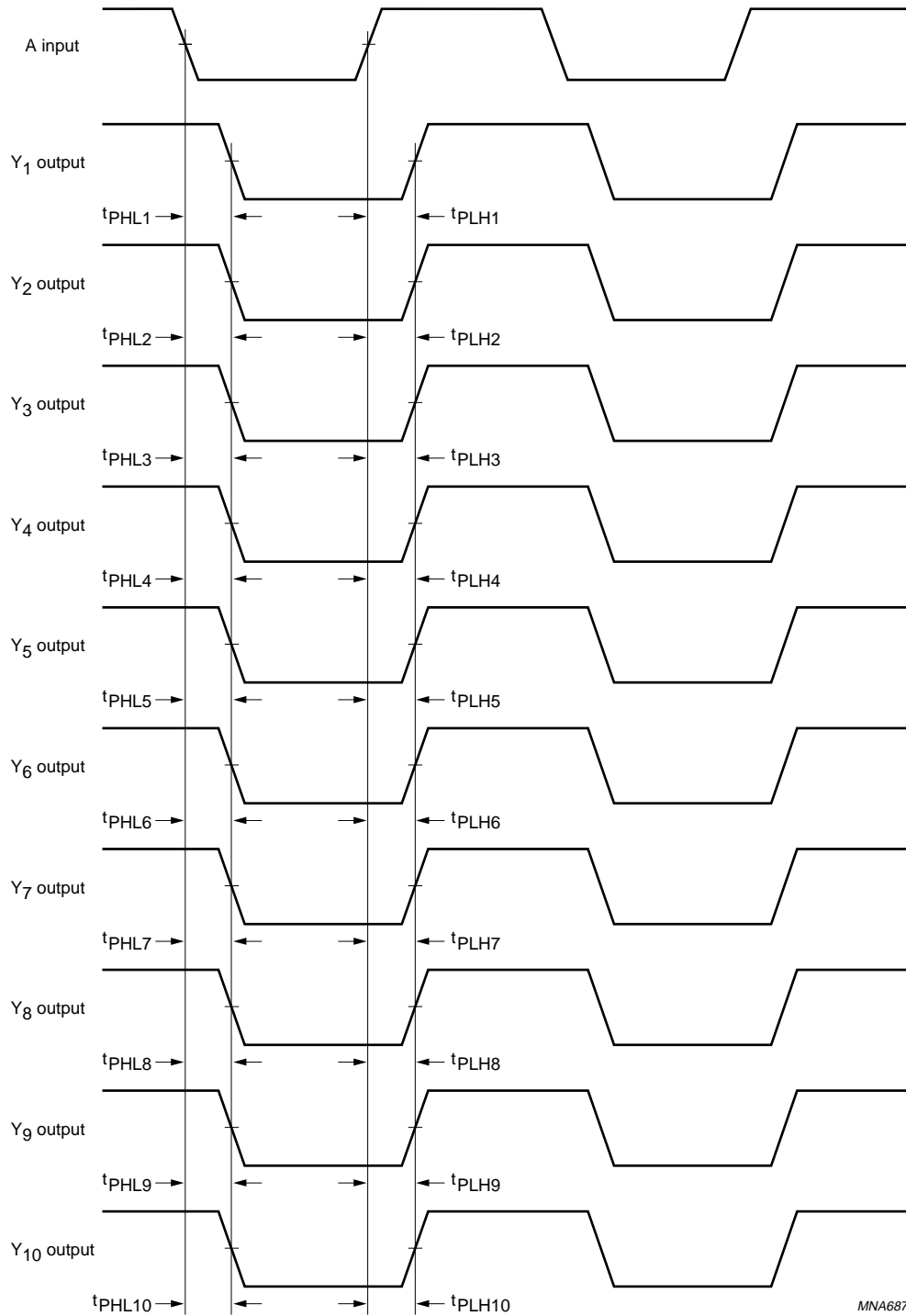

Fig.5 3-state enable and disable times.

1 : 10 clock distribution device with 3-state outputs

PTN3151



Output-to-output skew is the highest value of positive and negative edge skew:

$$t_{sk(o)} = t_{PLHn(max)} - t_{PLHn(min)} \text{ and } t_{sk(o)} = t_{PHLn(max)} - t_{PHLn(min)} \text{ for } n = 1 \text{ to } 10.$$

Output pulse skew is the highest value of: $t_{sk(p)} = |t_{PLHn} - t_{PHLn}|$ for $n = 1$ to 10 .

Part-to-part skew $t_{sk(pr)}$ represents the positive and negative edge skew between outputs of several devices operating under identical conditions.

Fig.6 Calculation of $t_{sk(o)}$, $t_{sk(p)}$ and $t_{sk(pr)}$.

1 : 10 clock distribution device with 3-state outputs

PTN3151

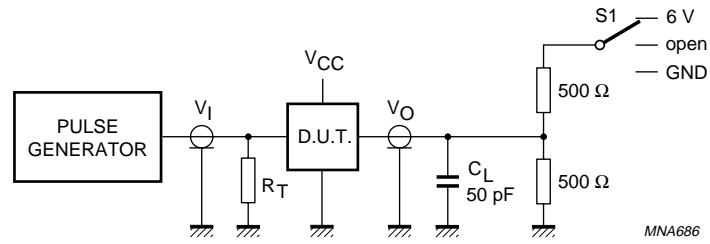

MNA686

TEST	S1
t_{PLH}/t_{PHL}	open
t_{PLZ}/t_{PZL}	6 V
t_{PHZ}/t_{PZH}	GND

Fig.7 Load circuitry for switching times.

1 : 10 clock distribution device with 3-state outputs

PTN3151

PACKAGE OUTLINES

SO24: plastic small outline package; 24 leads; body width 7.5 mm

SOT137-1

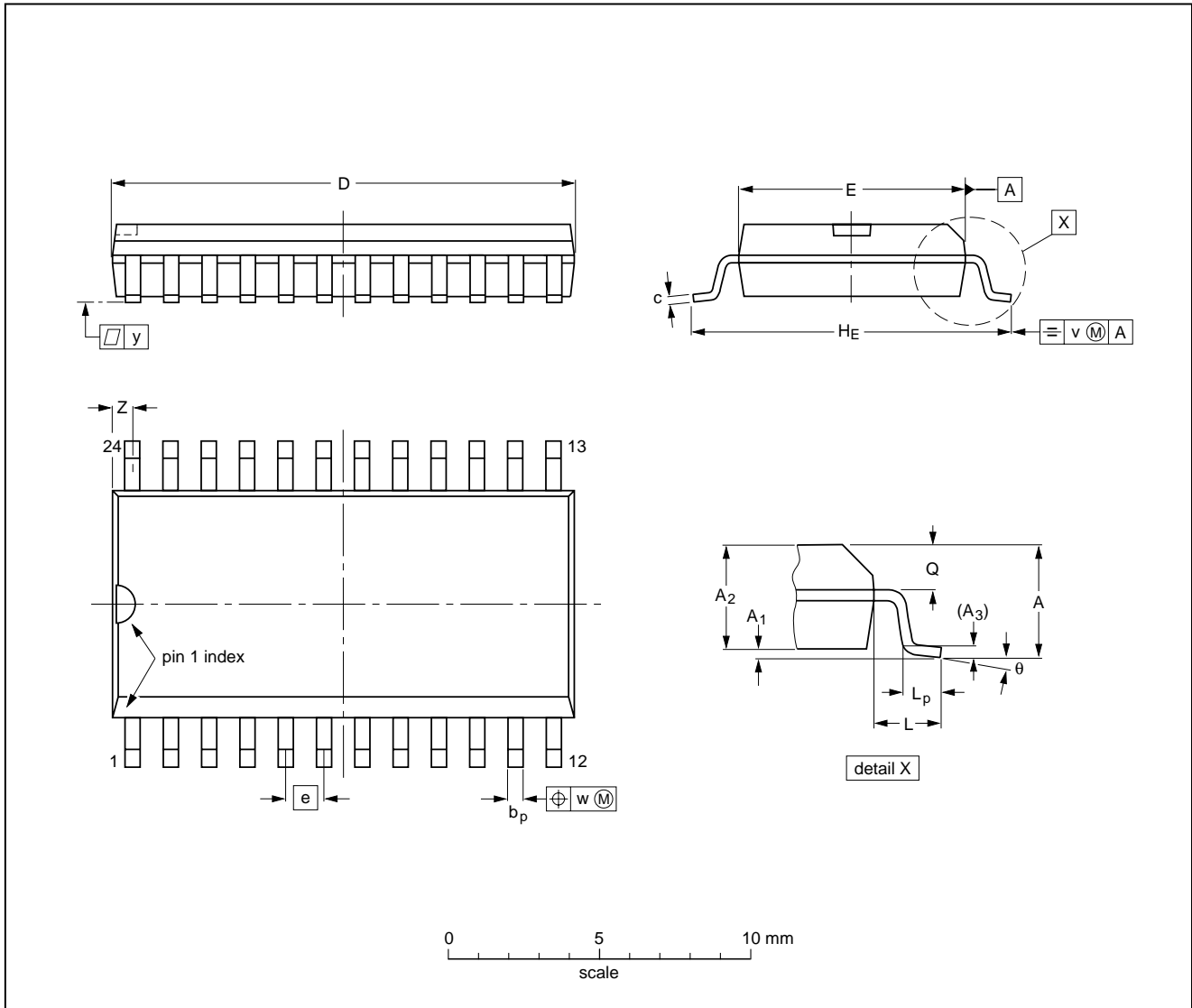

DIMENSIONS (inch dimensions are derived from the original mm dimensions)

UNIT	A max.	A ₁	A ₂	A ₃	b _p	c	D ⁽¹⁾	E ⁽¹⁾	e	H _E	L	L _p	Q	v	w	y	z ⁽¹⁾	θ
mm	2.65	0.30 0.10	2.45 2.25	0.25	0.49 0.36	0.32 0.23	15.6 15.2	7.6 7.4	1.27	10.65 10.00	1.4	1.1 0.4	1.1 1.0	0.25	0.25	0.1	0.9 0.4	8° 0°
inches	0.10	0.012 0.004	0.096 0.089	0.01	0.019 0.014	0.013 0.009	0.61 0.60	0.30 0.29	0.050	0.419 0.394	0.055	0.043 0.016	0.043 0.039	0.01	0.01	0.004	0.035 0.016	

Note

1. Plastic or metal protrusions of 0.15 mm maximum per side are not included.

OUTLINE VERSION	REFERENCES				EUROPEAN PROJECTION	ISSUE DATE
	IEC	JEDEC	EIAJ			
SOT137-1	075E05	MS-013				97-05-22 99-12-27

1 : 10 clock distribution device with 3-state outputs

PTN3151

SSOP24: plastic shrink small outline package; 24 leads; body width 5.3 mm

SOT340-1

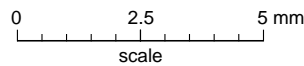
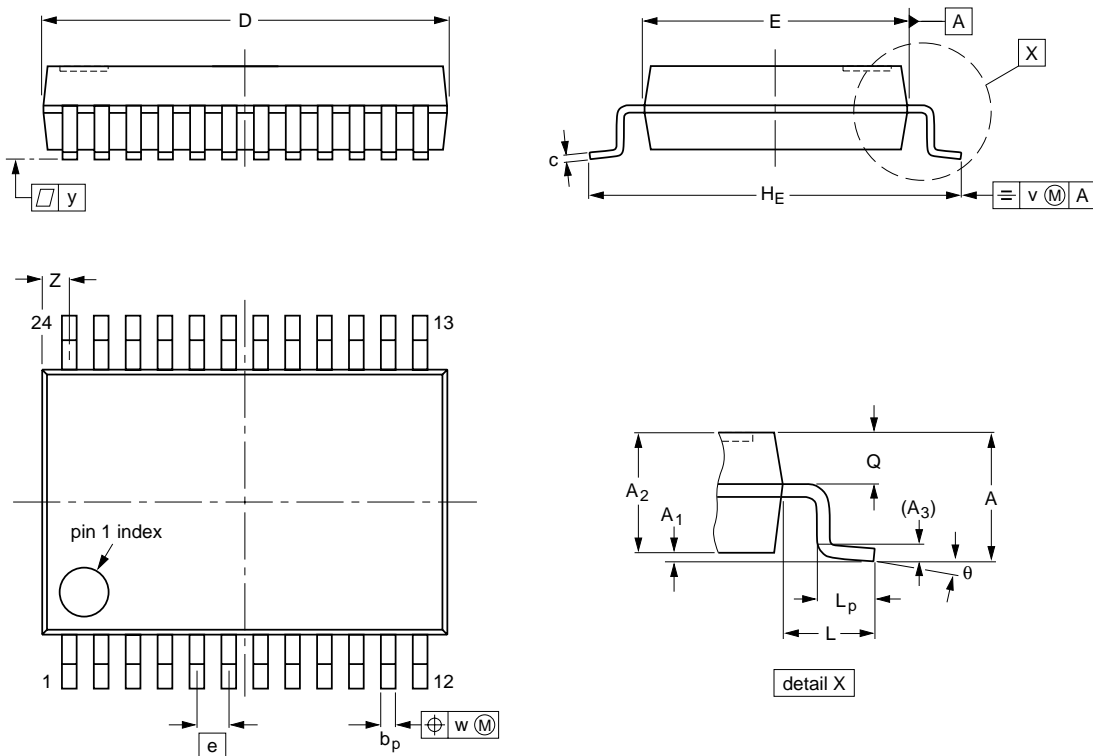

DIMENSIONS (mm are the original dimensions)

UNIT	A max.	A ₁	A ₂	A ₃	b _p	c	D ⁽¹⁾	E ⁽¹⁾	e	H _E	L	L _p	Q	v	w	y	Z ⁽¹⁾	θ
mm	2.0	0.21 0.05	1.80 1.65	0.25	0.38 0.25	0.20 0.09	8.4 8.0	5.4 5.2	0.65	7.9 7.6	1.25	1.03 0.63	0.9 0.7	0.2	0.13	0.1	0.8 0.4	8° 0°

Note

1. Plastic or metal protrusions of 0.20 mm maximum per side are not included.

OUTLINE VERSION	REFERENCES				EUROPEAN PROJECTION	ISSUE DATE
	IEC	JEDEC	EIAJ			
SOT340-1		MO-150				95-02-04 99-12-27

1 : 10 clock distribution device with 3-state outputs

PTN3151

SOLDERING**Introduction to soldering surface mount packages**

This text gives a very brief insight to a complex technology. A more in-depth account of soldering ICs can be found in our *"Data Handbook IC26; Integrated Circuit Packages"* (document order number 9398 652 90011).

There is no soldering method that is ideal for all surface mount IC packages. Wave soldering can still be used for certain surface mount ICs, but it is not suitable for fine pitch SMDs. In these situations reflow soldering is recommended.

Reflow soldering

Reflow soldering requires solder paste (a suspension of fine solder particles, flux and binding agent) to be applied to the printed-circuit board by screen printing, stencilling or pressure-syringe dispensing before package placement.

Several methods exist for reflowing; for example, convection or convection/infrared heating in a conveyor type oven. Throughput times (preheating, soldering and cooling) vary between 100 and 200 seconds depending on heating method.

Typical reflow peak temperatures range from 215 to 250 °C. The top-surface temperature of the packages should preferably be kept below 220 °C for thick/large packages, and below 235 °C for small/thin packages.

Wave soldering

Conventional single wave soldering is not recommended for surface mount devices (SMDs) or printed-circuit boards with a high component density, as solder bridging and non-wetting can present major problems.

To overcome these problems the double-wave soldering method was specifically developed.

If wave soldering is used the following conditions must be observed for optimal results:

- Use a double-wave soldering method comprising a turbulent wave with high upward pressure followed by a smooth laminar wave.
- For packages with leads on two sides and a pitch (e):
 - larger than or equal to 1.27 mm, the footprint longitudinal axis is **preferred** to be parallel to the transport direction of the printed-circuit board;
 - smaller than 1.27 mm, the footprint longitudinal axis **must** be parallel to the transport direction of the printed-circuit board.

The footprint must incorporate solder thieves at the downstream end.

- For packages with leads on four sides, the footprint must be placed at a 45° angle to the transport direction of the printed-circuit board. The footprint must incorporate solder thieves downstream and at the side corners.

During placement and before soldering, the package must be fixed with a droplet of adhesive. The adhesive can be applied by screen printing, pin transfer or syringe dispensing. The package can be soldered after the adhesive is cured.

Typical dwell time is 4 seconds at 250 °C.

A mildly-activated flux will eliminate the need for removal of corrosive residues in most applications.

Manual soldering

Fix the component by first soldering two diagonally-opposite end leads. Use a low voltage (24 V or less) soldering iron applied to the flat part of the lead. Contact time must be limited to 10 seconds at up to 300 °C.

When using a dedicated tool, all other leads can be soldered in one operation within 2 to 5 seconds between 270 and 320 °C.

1 : 10 clock distribution device with 3-state outputs

PTN3151

Suitability of surface mount IC packages for wave and reflow soldering methods

PACKAGE	SOLDERING METHOD	
	WAVE	REFLOW ⁽¹⁾
BGA, LFBGA, SQFP, TFBGA	not suitable	suitable
HBCC, HLQFP, HSQFP, HSOP, HTQFP, HTSSOP, SMS	not suitable ⁽²⁾	suitable
PLCC ⁽³⁾ , SO, SOJ	suitable	suitable
LQFP, QFP, TQFP	not recommended ⁽³⁾⁽⁴⁾	suitable
SSOP, TSSOP, VSO	not recommended ⁽⁵⁾	suitable

Notes

1. All surface mount (SMD) packages are moisture sensitive. Depending upon the moisture content, the maximum temperature (with respect to time) and body size of the package, there is a risk that internal or external package cracks may occur due to vaporization of the moisture in them (the so called popcorn effect). For details, refer to the Drypack information in the *"Data Handbook IC26; Integrated Circuit Packages; Section: Packing Methods"*.
2. These packages are not suitable for wave soldering as a solder joint between the printed-circuit board and heatsink (at bottom version) can not be achieved, and as solder may stick to the heatsink (on top version).
3. If wave soldering is considered, then the package must be placed at a 45° angle to the solder wave direction. The package footprint must incorporate solder thieves downstream and at the side corners.
4. Wave soldering is only suitable for LQFP, TQFP and QFP packages with a pitch (e) equal to or larger than 0.8 mm; it is definitely not suitable for packages with a pitch (e) equal to or smaller than 0.65 mm.
5. Wave soldering is only suitable for SSOP and TSSOP packages with a pitch (e) equal to or larger than 0.65 mm; it is definitely not suitable for packages with a pitch (e) equal to or smaller than 0.5 mm.

1 : 10 clock distribution device with 3-state outputs

PTN3151

DATA SHEET STATUS

DATA SHEET STATUS ⁽¹⁾	PRODUCT STATUS ⁽²⁾	DEFINITIONS
Objective data	Development	This data sheet contains data from the objective specification for product development. Philips Semiconductors reserves the right to change the specification in any manner without notice.
Preliminary data	Qualification	This data sheet contains data from the preliminary specification. Supplementary data will be published at a later date. Philips Semiconductors reserves the right to change the specification without notice, in order to improve the design and supply the best possible product.
Product data	Production	This data sheet contains data from the product specification. Philips Semiconductors reserves the right to make changes at any time in order to improve the design, manufacturing and supply. Changes will be communicated according to the Customer Product/Process Change Notification (CPCN) procedure SNW-SQ-650A.

Notes

1. Please consult the most recently issued data sheet before initiating or completing a design.
2. The product status of the device(s) described in this data sheet may have changed since this data sheet was published. The latest information is available on the Internet at URL <http://www.semiconductors.philips.com>.

DEFINITIONS

Short-form specification — The data in a short-form specification is extracted from a full data sheet with the same type number and title. For detailed information see the relevant data sheet or data handbook.

Limiting values definition — Limiting values given are in accordance with the Absolute Maximum Rating System (IEC 60134). Stress above one or more of the limiting values may cause permanent damage to the device. These are stress ratings only and operation of the device at these or at any other conditions above those given in the Characteristics sections of the specification is not implied. Exposure to limiting values for extended periods may affect device reliability.

Application information — Applications that are described herein for any of these products are for illustrative purposes only. Philips Semiconductors make no representation or warranty that such applications will be suitable for the specified use without further testing or modification.

DISCLAIMERS

Life support applications — These products are not designed for use in life support appliances, devices, or systems where malfunction of these products can reasonably be expected to result in personal injury. Philips Semiconductors customers using or selling these products for use in such applications do so at their own risk and agree to fully indemnify Philips Semiconductors for any damages resulting from such application.

Right to make changes — Philips Semiconductors reserves the right to make changes, without notice, in the products, including circuits, standard cells, and/or software, described or contained herein in order to improve design and/or performance. Philips Semiconductors assumes no responsibility or liability for the use of any of these products, conveys no licence or title under any patent, copyright, or mask work right to these products, and makes no representations or warranties that these products are free from patent, copyright, or mask work right infringement, unless otherwise specified.

Philips Semiconductors – a worldwide company

Contact information

For additional information please visit <http://www.semiconductors.philips.com>. Fax: +31 40 27 24825

For sales offices addresses send e-mail to: sales.addresses@www.semiconductors.philips.com.

© Koninklijke Philips Electronics N.V. 2002

SCA74

All rights are reserved. Reproduction in whole or in part is prohibited without the prior written consent of the copyright owner.

The information presented in this document does not form part of any quotation or contract, is believed to be accurate and reliable and may be changed without notice. No liability will be accepted by the publisher for any consequence of its use. Publication thereof does not convey nor imply any license under patent- or other industrial or intellectual property rights.

Printed in The Netherlands

613508/01/pp16

Date of release: 2002 Jan 14

Document order number: 9397 750 09269

Let's make things better.

**Philips
Semiconductors**



PHILIPS